

# PHILCO . . . . . Model 37-675



## FOR MEMBERS OF RADIO MANUFACTURERS SERVICE

## SERVICE BULLETIN No. 261

### Model 37-675 - Codes 121-122

#### Electrical Specifications

**Type of Circuit:** Superheterodyne with Magnetic Tuning; Spread-band dial; Philco Foreign Tuning System, and a class "A" Audio Output Circuit. Code 122 receiver has the Philco Automatic Dial tuning system.

**Power Supply:** 115 Volts A.C. 50 to 60 cycles or 25 to 40 cycle. Power transformer Part Numbers for the different voltage and frequency ranges are listed on Page 5.

**Power Consumption:** 155 Watts.

**Intermediate Frequency:** 470 K.C.

**Undistorted Output:** 10 Watts.

**Philco Tubes Used:** Twelve (12)—3-6K7G; 3-6F6G; 1-6L7G; 1-6N7G; 1-6A8G; 1-6Q7G; 1-6H6G; 1-5X4G.

**Tuning Ranges:** Five—Range 1—530 to 1600 K.C.; Range 2—1.58 to 4.75 M.C.; Range 3—4.7 to 7.4 M.C.; Range 4—7.35 to 11.6 M.C.; Range 5—11.5 to 18.2 M.C.

**Tone Control:** Twin Tone Controls—  
A. Continuously variable treble control  
B. Three point variable bass compensation

**Speaker:** U-15.

#### Aerial Connections

To obtain the full advantage of the sensitivity of this receiver the Philco High Efficiency Aerial supplied with the receiver must be used. The connections for the aerial are as follows:

The red and black leads of the High-Efficiency Aerial "transmission line" are connected to terminals 1 and 2 respectively, of the terminal panel provided on the rear of the chassis. Connect the jumper on the terminal panel across terminals 3 and 4.

If a temporary aerial is used, the jumper should be across terminals 2 and 3. The aerial connects to terminal 1 and the ground lead to terminal 3. A good ground connection is desirable in all installations.

#### DIAL CALIBRATION

In order to adjust this receiver correctly the dial must be aligned to track properly with the tuning condenser. To do this proceed as follows:

1. Loosen the set screws on the shaft coupling of the tuning condenser. Then turn the tuning condenser until the plates are in the maximum capacity position. Now set the glowing beam indicator on the index line at the low frequency end of the broadcast band. With dial and tuning condenser in this position tighten set screws.

2. Turn the tuning condenser control until the indicator is on the first division from the index line.

3. With the dial in this position, loosen the shaft coupling set screws. Then turn the dial until the indicator is again on the index line. Tighten the set screws in this position.

NOTE: Be careful when turning the dial that the position of the tuning condenser is not disturbed.

#### REPLACING AUTOMATIC DIAL CONTROL SCREWS Code 122

See Bulletin 258 for the procedure on removal of the Automatic Dial Control screws.

#### REPLACING THE DIAL OR MASK ARM ASSEMBLY Code 122

To replace the dial or mask arm assembly, remove the chassis from the cabinet. Then remove the dial tuning knobs. Take off the control handle cover by removing the three screws holding it to the handle hub. When the metal cover is removed, two screws will be noted holding the control handle to the rotary hub. Remove the screws and detach the handle.

Now remove the five screws holding the dial escutcheon plate to the dial body and lift the escutcheon from the dial body. With these parts removed, the dial may be detached.

#### MASK ASSEMBLY—Code 122

With the dial removed, two fibre rings and one metal ring will be found around the outer side of the dial housing. Take off these rings and slip the mask from the housing.

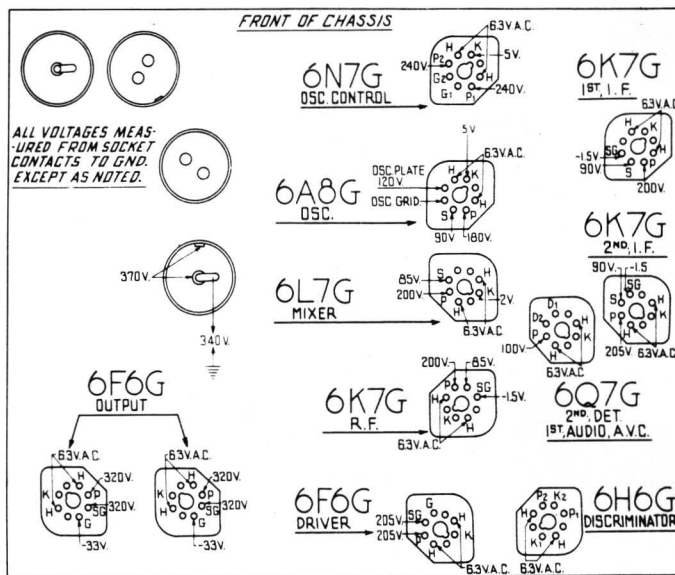

Fig. 1—Socket Voltages, Measured from Underside of Chassis

The voltages indicated by arrows were measured with a Philco 025 Circuit Tester which contains a voltmeter having a resistance of 1000 ohms per volt. Volume Control at minimum, range switch in broadcast position, line voltage 115 A. C.

#### SHADOWMETER ADJUSTMENT—Code 121

Remove aerial and allow tubes to warm up. Then adjust shadow meter as follows:

1. Move the shadow meter coil backwards and forwards, until the opposite edges of the shadow are 1/8 of an inch from end of the shadow screen, measuring along the bottom edge of the screen. Adjustment of the shadow meter light bracket may be necessary for perfect centering.

2. Remove the rectifier tube from its socket, and rotate coil until shadow reaches minimum width. This width must not exceed 3/32 of an inch.

3. Replace the 5X4G rectifier tube in its socket. The shadow should then widen to not more than 3/16 inch or less than 1/16 inch from each side of the screen measuring along the bottom edge. If these limits are not obtained readjust the shadow meter as given in paragraphs 1 and 2 until they are reached.

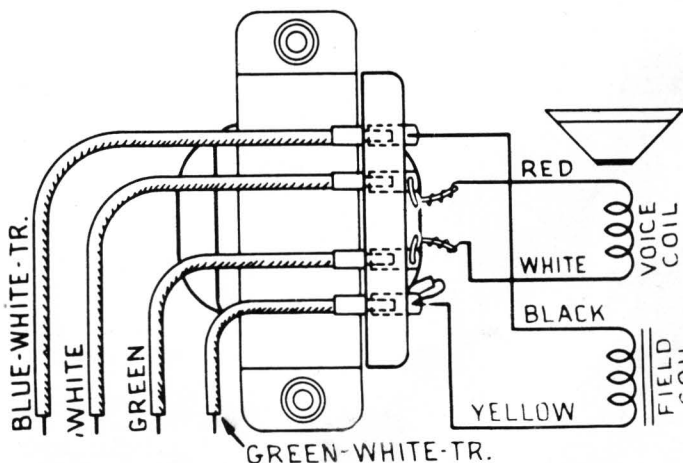

Fig. 2—U15 Speaker Wiring

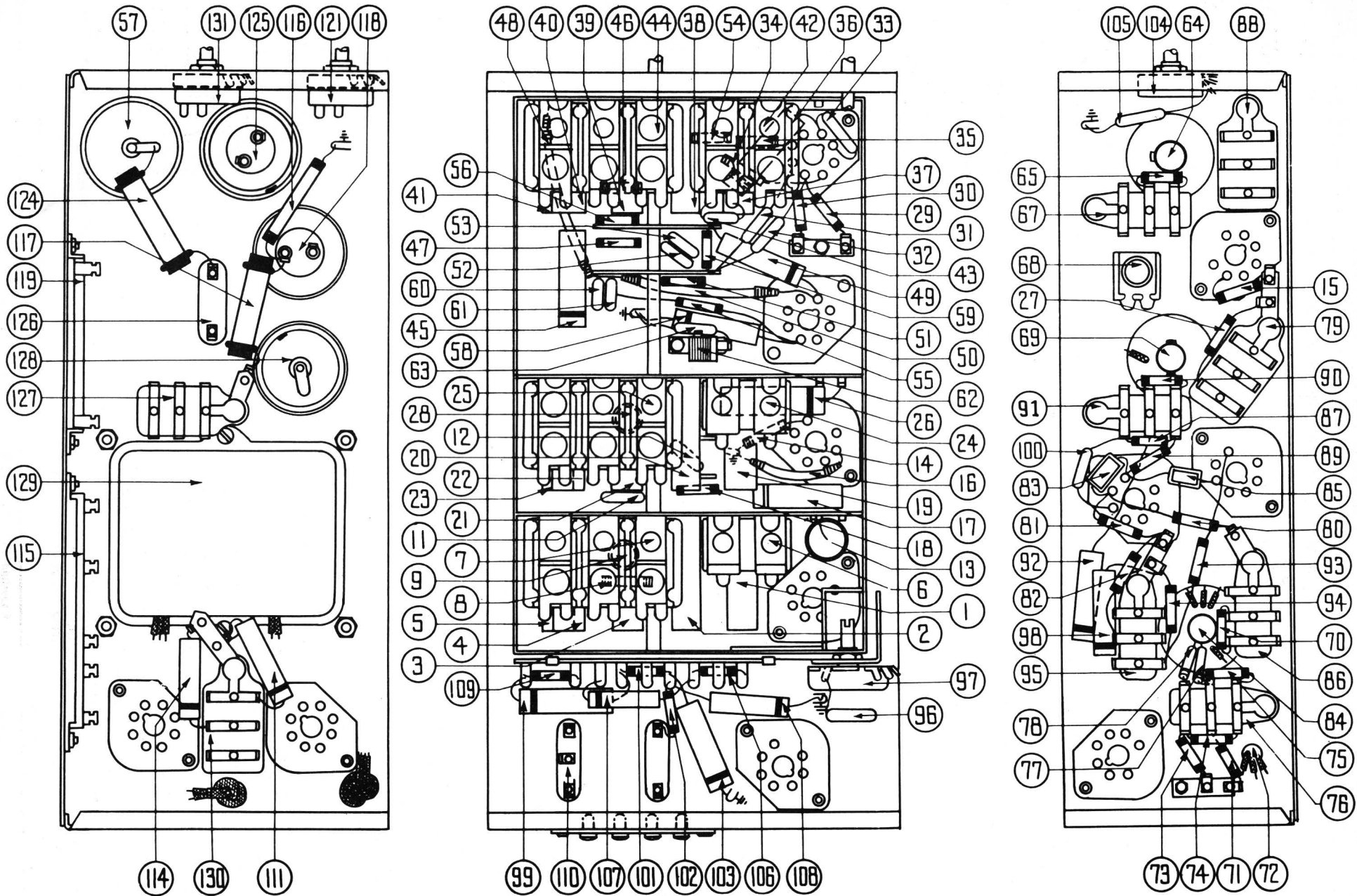

Fig. 3—Parts locations. Underside of Chassis

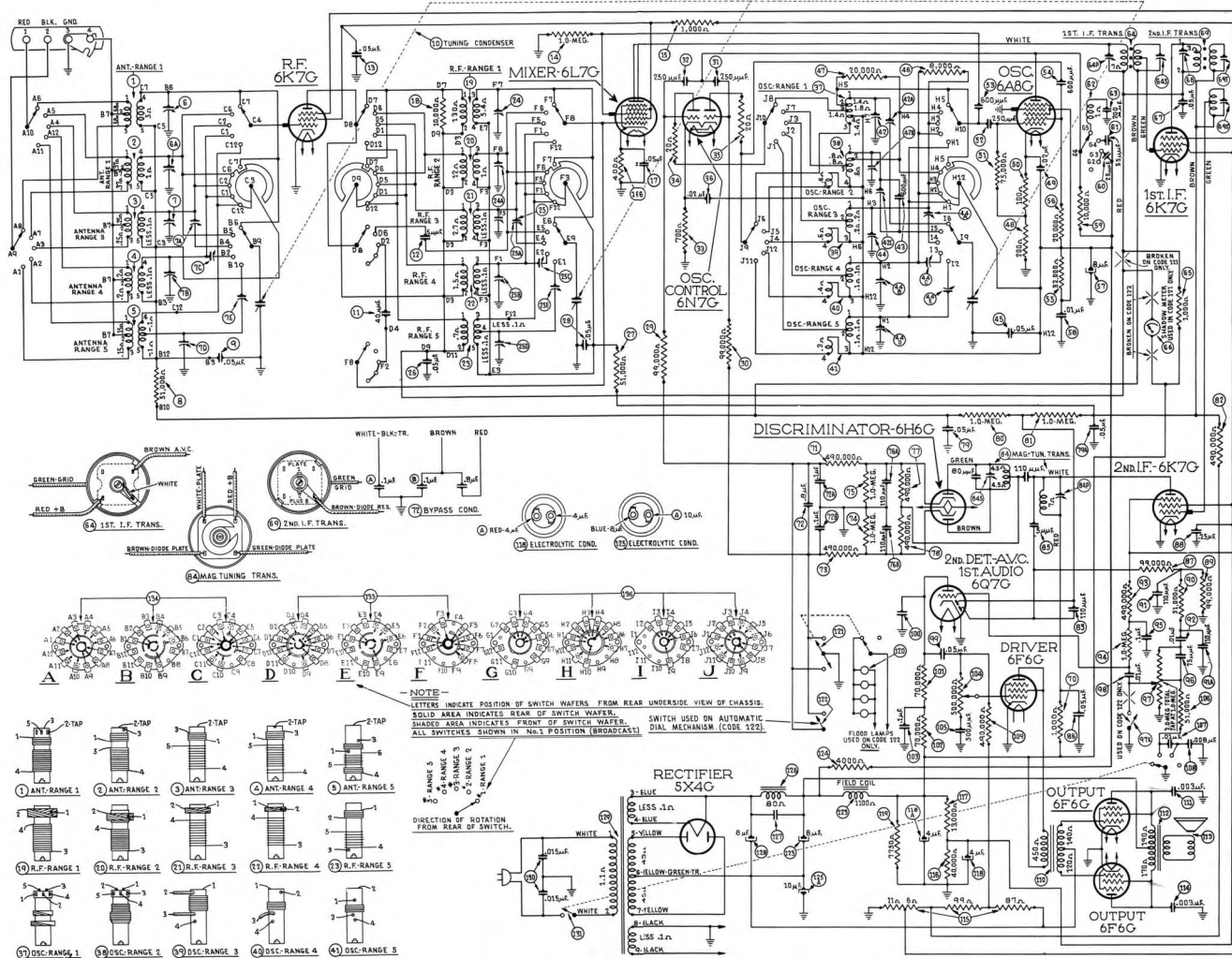

Fig. 4—Schematic Diagram Model 37-675—Codes 121-122

### Alignment of the Compensators

To accurately adjust this receiver, precision test equipment is necessary. A signal generator such as the PHILCO MODEL 088 SIGNAL GENERATOR, covering from 110 to 20,000 K. C. is designed for adjusting the compensators at the various frequencies specified. A visual indication of the receiver output is also necessary to obtain correct adjustment of the compensators. PHILCO MODEL 025 CIRCUIT TESTER contains a sensitive output meter and is recommended for these adjustments.

Philco Fibre Handle Screw-driver No. 27-7059 completes the necessary equipment for these adjustments. The locations of the various compensators are shown in Figs. 5 and 6.

**NOTE**—The receiver should be allowed to heat for at least 15 minutes before adjusting the compensators.

#### OUTPUT METER

The 025 Output Meter is connected to the plate and cathode terminals of the 6F6G driver tube. Adjust the meter to use the (0-30) Volt Scale.

#### INTERMEDIATE FREQUENCY CIRCUIT

##### Frequency 470 K. C.

**IMPORTANT**—Before adjusting the compensators, calibrate tuning dial as given on Page 1.

1. Connect the 088 Signal Generator output lead in series with a 1 mfd. condenser to the grid of the 6K7G tube, 2nd I.F., and the ground connection of the output lead to the chassis.

2. Set the receiver volume control in the maximum position; tone control counter-clockwise; Magnetic Tuning Switch "Off" (counter-clockwise); range switch in position No. 1 (Broadcast); bass compensation switch on first tap from "off" position, and the receiver dial to approximately 580 K. C. Adjust the signal generator for 470 K. C.

3. Now adjust compensator (84P) for maximum output.

4. Remove the signal generator output lead with the .1 mfd. condenser from the 6K7G 2nd I.F. grid and connect them to the 6K7G, 1st I.F. grid.

5. Turn compensator (69T) clockwise until it is tight, then adjust compensators (68) and (69S) for maximum output. Now adjust compensator (69T) for maximum output. Caution: Do not adjust compensators (68) and (69S) unless compensator (69T) is turned to the extreme clockwise position.

6. Remove the signal generator output lead and condenser from the 6K7G, 1st I.F. tube and connect them to the grid of the 6L7G tube, 1st detector, and adjust compensators (64P) and (64S) for maximum output.

#### RADIO FREQUENCY CIRCUIT

##### Tuning Range 11.5-18.2 M. C.

1. The signal generator output lead with the .1 mfd. condenser, is connected to terminal No. 1 on the aerial input panel (rear of chassis) and the generator ground lead to terminal No. 3. Terminals 2 and 3 must be connected with the shorting link provided on the panel.

2. Set the magnetic tuning control in the "off" position. Set the range switch in position No. 5 (11.5 to 18.2 M. C.). Turn the receiver and signal generator dials to 18 M. C. and adjust the generator attenuator for a readable indication on the output meter. Now adjust compensator (44D) by turning the screw (clockwise) to the maximum capacity position, then slowly turn it counter-clockwise until a second maximum peak is reached on the output meter. The first peak from maximum capacity is the image signal and the receiver *must not* be adjusted to this signal. On some receivers, however, only one peak will be found, therefore, adjust compensator (44D) to this peak. If the above procedure is correctly performed, the image signal will be found at 17.06 M. C. by advancing the signal generator input, and turning the receiver dial to this frequency mark on the scale.

3. Leaving the signal generator and receiver dials at 18 M. C. the antenna and R. F. compensators (7D) and (25D) are now adjusted by connecting a variable condenser (Philco Part No. 45-2325) across the oscillator compensator (44D) contact (first contact from the left side of the receiver facing rear underside view of the chassis) and ground. Now tune the added condenser until the second harmonic of the receiver oscillator beats against the signal from the generator, resulting in a maximum indication on the output meter. Note: it may be necessary to increase the signal generator output to obtain a signal of sufficient strength for reading on the output meter. Compensators (7D) and (25D) are now adjusted for maximum output. After these adjustments, remove the external condenser and readjust compensator (44D) as given in paragraph 2 above.

4. Turn the signal generator and receiver dials to 12 M. C. and adjust compensators (44E), (25E) and (7E) for maximum output.

5. Readjust compensator (44D) as given in paragraph 2 above, for maximum output.

6. Readjust compensators (7D), (25D) and (44D) as given in paragraph 3 above. This readjustment is to correct any variation that the low frequency compensator may have caused in the high end of this range.

##### Tuning Range (7.35-11.6 M. C.)

1. Turn selector switch to Range 4. Set the signal generator and receiver dials to 11.0 M. C. Now adjust compensator (44B) for maximum output. Check for image at 10.06 M. C.

2. Leaving signal generator and receiver dial turned to 11.0 M. C., connect the external variable condenser across the oscillator compensator (44B) contact (third contact from left side of the receiver facing rear underside view of chassis) and ground. Tune the added condenser for maximum output, then adjust compensators (7B) and (25B) for maximum output. Remove the added condenser and adjust (44B) for maximum.

3. Turn the signal generator and receiver dials to 7.5 M. C. and adjust compensators (44C), (25C) and (7C) for maximum output.

4. Readjust compensator (44B) as given in paragraph 1 above.

5. Readjust compensators (7B), (25B) and (44B) as given in paragraph 2 above.

##### Tuning Range (4.7 to 7.4 M. C.)

1. Turn selector switch to range 3. Set the signal generator and receiver dials for 7.0 M. C. and adjust compensators (44), (25) and (7) for maximum output.

2. Rotate the signal generators and receiver dials to 5.0 M. C., then adjust compensators (44A), (25A) and (7A) for maximum output.

3. Readjust compensators (44), (25) and (7) on the 7.0 M. C. signal.

##### Tuning Range (1.58 to 4.75 M. C.)

1. Turn the selector switch to range 2. Set the signal generator and receiver dials to 4.5 M. C. Now adjust compensators (42B), (24A) and (6A) for maximum output.

2. Rotate the signal generator and receiver dials to 1.7 M. C. Compensator (42C) Osc. series is now adjusted for maximum output as follows: First tune compensator (42C) for maximum output, then vary the tuning condenser of the receiver for maximum output about the 1.7 M. C. dial mark. Now turn compensator (42C) slightly to the right or left and vary the receiver tuning condenser for maximum output. If the output reading increases, turn compensator (42C) in the same direction a trifle more, and again vary the tuning condenser for maximum output. If the output decreases, set the compensator in the opposite direction. This procedure of first setting the compensator and then varying the tuning condenser is continued until there is no further gain in output reading.

3. Readjust compensators (42B), (24A) and (6A) for maximum output as given in paragraph 1 above.

##### Tuning Range (530 to 1600 K. C.)

1. Set selector switch in range 1. Rotate the signal generator and receiver dial to 1500 K. C. Adjust compensators (42), (24) and (6) for maximum output.

2. Turn the signal generator and receiver dials to 580 K. C. Compensator (42A) Osc. series is now adjusted, using the same procedure as given in paragraph 2 under Tuning Range (1.58 to 4.75 M. C.). The only difference in the two adjustments is the frequency and compensator used.

3. Readjust compensator (42), on 1500 K. C. and compensators (24) and (6) on a 1400 K. C. signal.

#### ADJUSTMENT OF THE MAGNETIC TUNING CONTROL

1. Leaving the selector switch in position 1. Set the Magnetic tuning switch in the "out" position. Turn the signal generator and dial to 1000 K. C., then adjust the receiver dial for maximum output.

**NOTE:** It is very important to accurately adjust the receiver tuning condenser for peak output, also, adjust the signal generator attenuator to maximum output position.

2. Turn the (Magnetic Tuning Control) to the "on" position (clockwise). Compensator (84S) Sec. of magnetic tuning transformer is now adjusted for maximum output. If the indicator of the output meter goes off scale, turn the volume control of the receiver toward the minimum position until a readable indication is obtained.

3. The above adjustment is now checked for accuracy, by turning the magnetic tuning control "off". When this is done there should be no change in the tone of the received signal. If a change of tone or hiss develops, it indicates a shift in frequency and the adjustment must be made again.

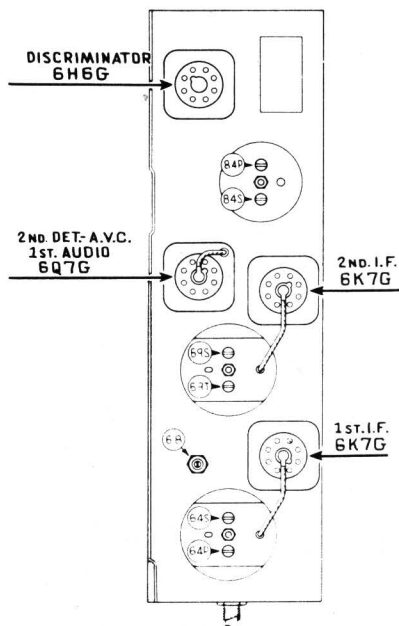

Fig. 5—Locations of I.F. Compensators Top of I.F. Unit

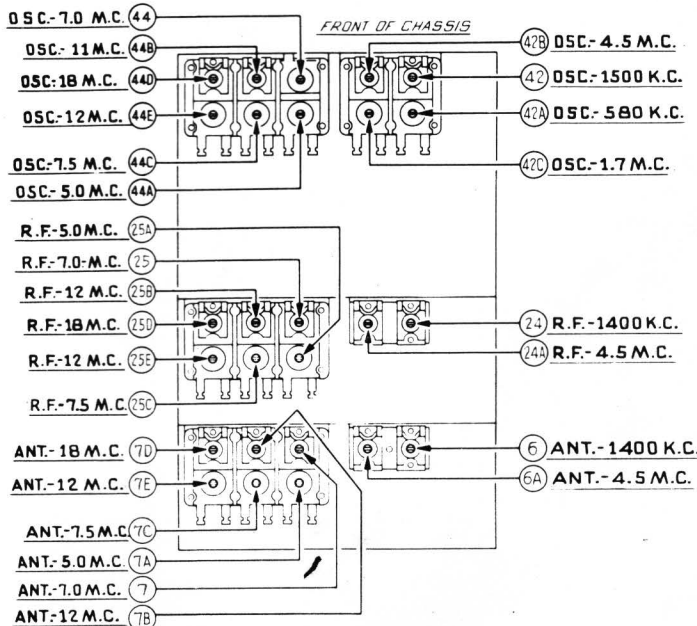

Fig. 6—Locations of R.F. Compensators Underside of Chassis View

Replacement Parts—Model 37-675—Codes 121-122

Schem. No.	Description	Part No.	List Price	Schem. No.	Description	Part No.	List Price	Schem. No.	Description	Part No.	List Price
1	Antenna Transformer (Range 1)	32-2108	\$0.80	78	Resistor (490000 ohms 1/2 watt)	33-449339	\$0.20		Tube Shield Base	28-3898	\$0.03
2	Antenna Transformer (Range 2)	32-2146	.80	79	Condenser (.05 mfd. dual bakelite)	3615-DG	.40		Tube Shield (6N7G)	8005	.10
3	Antenna Transformer (Range 3)	32-2183	.60	80	Resistor (1.0 megohm 1/2 watt)	33-510339	.20		Tube Shield Base (6N7G)	8004	.03
4	Antenna Transformer (Range 4)	32-2185	.70	81	Resistor (1.0 megohm 1/2 watt)	33-510339	.20		Mtg. Grommet (R. F. Unit)	27-4317	.01
5	Antenna Transformer (Range 5)	32-2175	.80	82	Resistor (490000 ohms 1/2 watt)	33-449339	.20		Mtg. Sleeve (R. F. Unit)	28-2257	.01
6	Compensator (2 sections)	31-6093	.40	83	Condenser (110 mmfd. mica)	30-1031	.20		Mtg. Screw (R. F. Unit)	W-729	.45 C
7	Compensator (6 sections)	31-6112	1.40	84	Magnetic Tuning Transformer	32-2217	2.40		Mtg. Spacer (R. F. Unit) code 121	27-8339	.40 C
8	Resistor (51000 ohms 1/2 watt)	33-351339	.20	85	Condenser (5 mmfd. mica)	30-1083	.20		Mtg. Spacer (R. F. Unit) code 122	27-7807	.50 C
9	Condenser (.05 mfd. tubular)	30-4020	.20	86	Condenser (.05 mfd. bakelite)	3615-SG	.35		Mtg. Washer	28-3927	.01
10	Tuning Condenser	31-1892	3.75	87	Resistor (99000 ohms 1/2 watt)	33-399339	.20		Mtg. Rubber (Tuning Condenser)	27-4325	.02
11	Condenser (40 mmfd. mica)	30-1076	.20	88	Condenser (.25 mfd. bakelite)	6287-DG	.40		Mtg. Rubber (Chassis)	3558	.03
12	Condenser (5 mmfd. mica)	30-1077	.20	89	Resistor (99000 ohms 1/2 watt)	33-399339	.20		Mtg. Bushing	27-4360	.04
13	Condenser (.05 mfd. tubular)	30-4123	.20	90	Resistor (51000 ohms 1/2 watt)	33-351339	.20		Mtg. Plate (R. F. Transformer)	28-3808	.02
14	Resistor (1 megohm 1/2 watt)	33-510339	.20	91	Condenser (110 mmfd. dual bakelite)	8035-DG	.25		Mtg. Spacer (R. F. Transformer)	27-8228	.01
15	Resistor (1000 ohms 1/2 watt)	33-210339	.20	92	Condenser (.01 mfd. tubular)	30-4124	.25		Mtg. Screw (R. F. Transformer)	W-1635	.30 C
16	Resistor (400 ohms wirewound)	33-3016	.20	93	Resistor (490000 ohms 1/2 watt)	33-449339	.25		Terminal Panel (Ant.)	38-7714	.15
17	Condenser (.05 mfd. tubular)	30-4444	.20	94	Resistor (1 megohm 1/2 watt)	33-510339	.25		Terminal Cover (Speaker)	36-3672	.15
18	Resistor (10000 ohms 1/2 watt)	33-310339	.20	95	Condenser (.1 mfd. bakelite)	4989-SG	.35		Knob (Tuning)	27-4330	.10
19	R. F. Transformer (Range 1)	32-2105	.75	96	Condenser (75 mmfd. mica)	30-1053	.20		Knob, Vernier	27-4331	.10
20	R. F. Transformer (Range 2)	32-2147	.60	97	Volume Control	33-5158	1.00		Knob, Tone & Volume	27-4332	.10
21	R. F. Transformer (Range 3)	32-2177	.60	97X	Ring & Contact Assem. (For shorting volume control Code 122 dial)	45-2350			Knob, Range Switch	27-4326	.10
22	R. F. Transformer (Range 4)	32-2178	.60	98	Condenser (.01 mfd. tubular)	30-4124	.25		Cable (Speaker)	41-3223	
23	R. F. Transformer (Range 5)	32-2176	.70	99	Condenser (.05 mfd. tubular)	30-4449	.20		A. C. Plug & Cord	L-2288	.40
24	Compensator (2 sections)	31-6093	.40	100	Condenser (110 mmfd. mica)	30-1031	.20		Fuses	45-2046	.05
25	Compensator (6 sections)	31-6113	1.40	101	Resistor (70000 ohms 1/2 watt)	33-370339	.20		Bottom Shield Plate	38-8143	
26	Condenser (.05 mfd. tubular)	30-4123	.20	102	Resistor (70000 ohms 1/2 watt)	33-370339	.20		Snap Fasteners	28-4279	.75 C
27	Resistor (51000 ohms 1/2 watt)	33-351339	.20	103	Condenser (.1 mfd. tubular)	30-4455	.25		Speaker (U-15)	36-1252	16.00
28	Condenser (.05 mfd. tubular)	30-4020	.20	104	Tone Control	33-5173			<b>CODE 121</b>		
29	Resistor (99000 ohms 1/2 watt)	33-399339	.20	105	Condenser (500 mmfd. mica)	30-1086	.20		Dial	27-5249	.40
30	Resistor (99000 ohms 1/2 watt)	33-399339	.20	106	Resistor (51000 ohms 1/2 watt)	33-351339	.20		Hub	28-7187	.12
31	Condenser (250 mmfd. mica)	30-1032	.25	107	Condenser (.01 mfd. tubular)	30-4169	.20		Clamp	28-2837	.10
32	Condenser (250 mmfd. mica)	30-1032	.25	108	Condenser (.008 mfd. tubular)	30-4112	.20		Set Screw	W-1641	.02
33	Resistor (700 ohms wirewound)	33-170339	.20	109	Resistor (490000 ohms 1/2 watt)	33-449339	.20		Dial Screen Holder Assembly	31-1945	
34	Resistor (20 ohms 1/2 watt)	33-020339	.20	110	Transformer (Audio Input)	32-7057	.20		Drive Mtg. Assembly	31-1901	1.80
35	Resistor (20 ohms 1/2 watt)	33-020339	.20	111	Condenser (.003 mfd. tubular)	30-4469	.20		Vernier Drive	31-1895	
36	Condenser (.02 mfd. tubular)	30-4481	.25	112	Output Transformer	32-7889	2.00		Gear (Dial)	28-7185	.10
37	Osc. Transformer (Range 1)	32-2191	.80	113	Cone-Voice Coil U-15	36-3631	1.75		Thrust Spring	28-8611	.01
38	Osc. Transformer (Range 2)	32-2194	.80	114	Condenser (.003 mfd. tubular)	30-4469	.20		Thrust Washer	28-3976	.30 C
39	Osc. Transformer (Range 3)	32-2197	.50	115	Resistor (203 ohms 3 taps wirewound)	33-3290	.60		"O" Washer	28-3904	.01
40	Osc. Transformer (Range 4)	32-2198	.50	116	Resistor (40000 ohms 1 watt)	33-340439	.20		Gear (Drive)	31-1884	.25
41	Osc. Transformer (Range 5)	32-2199	.50	117	Resistor (13000 ohms 2 watt)	33-313539	.30		Mask	27-5206	.30
42	Compensator (4 sections)	31-6124	1.00	118	Electrolytic Condenser (2 sections 4-4 mfd.)	30-2170	1.50		Mask Arm & Link Assembly	31-1899	.50
43	Condenser (600 mmfd. mica)	30-1049	.25	119	Resistor (7750 ohms wirewound)	33-3279	.55		Mask Washer	27-8318	.50 C
44	Compensator (6 section)	31-6117	1.20	120	Flood Lamp	34-2039	.07		Mask Guide & Bracket	38-7876	.25
45	Condenser (.05 mfd. tubular)	30-4123	.20	121	Magnetic Tuning Switch (Chassis)	42-1216	.75		Pilot Lamp Assembly	38-7909	.40
46	Resistor (8000 ohms 1/2 watt)	33-280339	.20	122	Magnetic Tuning Switch (Code 122 dial assembly)	45-2330			Bezel Frame & Plate Assembly	40-5948	.80
47	Resistor (20000 ohms 1/2 watt)	33-320339	.20	123	Field Coil Assembly U-15	36-3162	8.00		Glass	27-8300	.06
48	Resistor (200 ohms wirewound)	7217	.20	124	Resistor (4000 ohms 2 watts)	33-240539	.30		Ring	28-3988	.45
49	Condenser (.02 mfd. tubular)	30-4481	.25	125	Electrolytic Condenser (2 sections 8-10 mfd.)	30-2046	1.85		Gasket	27-8313	.01
50	Resistor (100 ohms wirewound)	33-3023	.25	126	Choke	32-7056	2.20		<b>CODE 122</b>		
51	Resistor (75000 ohms 1/2 watt)	33-375339	.20	127	Condenser (.15 mfd. dual bakelite)	6287-DG	.40		Dial Escutcheon Assembly	45-2324	
52	Condenser (250 mmfd. mica)	30-1032	.25	128	Electrolytic Condenser (8 mfd.)	30-2025	1.10		Auto Dial Tuning Assembly Complete	31-1886	25.00
53	Condenser (600 mmfd. mica)	30-1049	.25	129	Power Transformer 115 V. 50-60 cycles	32-7689	7.50		Dial Scale	27-5207	.80
54	Condenser (600 mmfd. mica)	30-1049	.25	130	Power Transformer 115 V. 25-40 cycles	32-7700			Dial Screen Holder Assembly	31-1946	
55	Resistor (32000 ohms 1/2 watt)	33-323339	.20	131	Power Transformer 220 V. 50-60 cycles	32-7701			Gasket (Dial Scale)	27-8398	.01
56	Resistor (20000 ohms 1/2 watt)	33-320339	.20	132	Condenser (twin bakelite .015 mfd.)	3793-DG	.40		Mask & Link Assembly	45-2328	
57	Electrolytic Condenser (8 mfd.)	30-2024	1.10	133	Base Compensation & A. C. Switch	42-1195	.75		Mask Guide	28-4118	.25
58	Condenser (.01 mfd. tubular)	30-4169	.20	134	Pilot Lamp (Dial)	34-2039	.07		Ring (Retaining Mask Assembly)	28-7195	.20
59	Resistor (10000 ohms 1/2 watt)	33-310339	.20	135	Shadowmeter Lamp (Code 121 only)	34-2039	.07		Spring (Retaining Mask Assembly)	28-8629	.04
60	Condenser (25 mmfd. mica)	30-1067	.20	136	Range Switch (Ant.)	42-1211	1.60		Control Screw	31-1898	
61	Condenser (55 mmfd. mica)	30-1045	.20		Range Switch (R. F.)	42-1212	1.60		Range Switch Shaft Coupling	27-8198	.15
62	Coil (6ABG plate)	32-2242	.25		Range Switch (Osc.)	42-1217	2.00		Felt Washer	27-8399	.30 C
63	Condenser (200 mmfd. mica)	30-1047	.25		<b>Used on Code 121 and 122</b>				Washer	W-495	.30 C
64	1st I. F. Transformer	32-2209			Brace (Drive Mtg.)	28-4119	.05		Washer	W-495	.30 C
65	Resistor (1000 ohms 1/2 watt)	33-210339	.20		Coupling Assembly (drive)	31-1907	.45		Snap Fastener	28-4279	.75 C
66	Shadowmeter (Code 121 only)	45-2189	2.50		Shaft & Index Plate (Range Switch)	42-1208	.50		Control Handle	45-2329	
67	Condenser (.05 mfd. bakelite)	3615-SG	.35		Retaining Clip	28-4117	.40 C		Cover (Handle)	28-4077	.25
68	Compensator (Pri. 2nd I.F. Trans.)	32-2211			Socket (8 prong)	27-6058	.11		Set Screws (Handle)	28-6493	.02
69	2nd I. F. Transformer	33-210339	.20		Socket (7 prong)	27-6057	.11		Screws (Cover)	W-1669	.40 C
70	Resistor (1000 ohms 1/2 watt)	33-210339	.20		Socket (Power Transformer)	27-6061			Flood Lamp Assembly (single)	38-7937	
71	Resistor (490000 ohms 1/2 watt)	33-449339	.20		Tube Shield	28-2726	.10		Pilot Lamp Assembly	38-8051	.35
72	Condenser (1.-1.-.8 mfd. metal case)	30-4470	1.40						Bezel Assembly	40-5980	1.00
73	Resistor (490000 ohms 1/2 watt)	33-449339	.20						Bezel Gasket	27-8517	
74	Resistor (1 megohm 1/2 watt)	33-510339	.20						Screws	W-480	.55 C
75	Resistor (1 megohm 1/2 watt)	33-510339	.20						Station Tab Kit	40-6013	.90
76	Condenser (110 mfd. dual bakelite)	8035-DG	.25						Insulator Ring and Contact Assembly	27-8351	
77	Resistor (490000 ohms 1/2 watt)	33-449339	.20								

Figures in black type indicate circled figures in Base View. Prices Subject to Change Without Notice.

# New REDUCED PRICES on PHILCO VIBRATORS

Now Only **\$4.25** List . . . (formerly \$5.00)

Part No. 41-3186 . . . For all Philco sets up to 1936

Part No. 41-3170 . . . For 1936 Philcos and most other makes



**PHILCO RADIO & TELEVISION CORPORATION**

**Parts and Service Division**